

Электромагнитный расходомер серии LD



General

Smart electromagnetic flowmeter LD series is oriented for conductive liquid with conductance higher than 5us/cm . It can be used to measure the volume flow of conductive fluid in a closed pipeline. It is composed of sensor and converter and two versions are available: Compact version and separate version. It is widely applied in the flow measurement and control in the fields of chemical and petroleum industry, metallurgy industry, water and waste water, agriculture and irrigation, paper making, food and beverage industry and pharmaceutical industry.

Measuring Principles

Measuring range of the LD smart electromagnetic flowmeter determined on the basis of Faraday Law of Electromagnetic Induction: If lines of magnetic induction are cut through in magnetic field by conductive liquid. Based on the law, we install a pair of electrodes on both sides inside a pipe that runs perpendicularly to both the measuring tube axes and magnetic line of force, electromotive E will be generated between the electrodes. When flux needs measuring, conductive liquid is let go on velocity V through a magnetic field that is perpendicular to the flow direction. With the conductive liquid running through, a voltage that is proportional to average flowing velocity is to be induced. The voltage signal induced can be detected by two or more electrodes that contacts the liquid and then transmitted to converter for intellectual processing before being shown in LCD display outputting standend signals of $4-20\text{mA}$ or $0-1\text{kHz}$.

По вопросам продаж и поддержки обращайтесь:

Архангельск (8182)63-90-72
Астана +7(7172)727-132
Астрахань (8512)99-46-04
Барнаул (3852)73-04-60
Белгород (4722)40-23-64
Брянск (4832)59-03-52
Владивосток (423)249-28-31
Волгоград (844)278-03-48
Вологда (8172)26-41-59
Воронеж (473)204-51-73
Екатеринбург (343)384-55-89
Иваново (4932)77-34-06
Ижевск (3412)26-03-58
Иркутск (395) 279-98-46
Киргизия (996)312-96-26-47

Казань (843)206-01-48
Калининград (4012)72-03-81
Калуга (4842)92-23-67
Кемерово (3842)65-04-62
Киров (8332)68-02-04
Краснодар (861)203-40-90
Красноярск (391)204-63-61
Курск (4712)77-13-04
Липецк (4742)52-20-81
Магнитогорск (3519)55-03-13
Москва (495)268-04-70
Мурманск (8152)59-64-93
Набережные Челны (8552)20-53-41
Нижегород (831)429-08-12
Казахстан (772)734-952-31

Новокузнецк (3843)20-46-81
Новосибирск (383)227-86-73
Омск (3812)21-46-40
Орел (4862)44-53-42
Оренбург (3532)37-68-04
Пенза (8412)22-31-16
Пермь (342)205-81-47
Ростов-на-Дону (863)308-18-15
Рязань (4912)46-61-64
Самара (846)206-03-16
Санкт-Петербург (812)309-46-40
Саратов (845)249-38-78
Севастополь (8692)22-31-93
Симферополь (3652)67-13-56
Таджикистан (992)427-82-92-69

Смоленск (4812)29-41-54
Сочи (862)225-72-31
Ставрополь (8652)20-65-13
Сургут (3462)77-98-35
Тверь (4822)63-31-35
Томск (3822)98-41-53
Тула (4872)74-02-29
Тюмень (3452)66-21-18
Ульяновск (8422)24-23-59
Уфа (347)229-48-12
Хабаровск (4212)92-98-04
Челябинск (351)202-03-61
Череповец (8202)49-02-64
Ярославль (4852)69-52-93

Эл. почта: zau@nt-rt.ru || Сайт: <https://zyia.nt-rt.ru/>

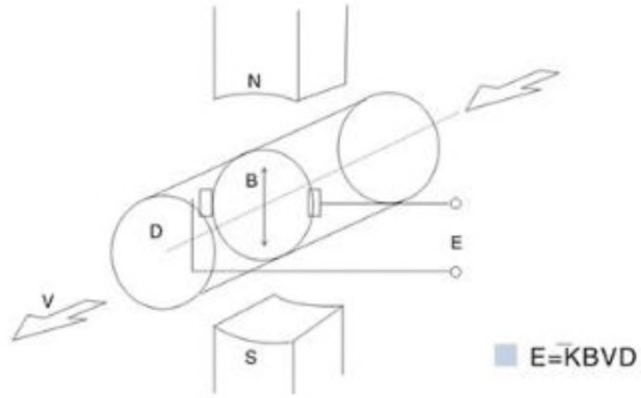

K---instrument modulus

B---density of magnetic induction

\bar{V} ---average flowing velocity through a section in tube

D---inner diameter of the tube

LD Series Electromagnetic Flowmeter

Features

- Various liner can be selected hat satisfies most industrial applications
- Flow velocity range: 0-12m/s, with good results for low flow applications
- It comes any flanges such as, ANSI DIN JIS Etc
- It excellent for high pressure application
- Protection class: IP68 is available, and the sensor can sink into the water
- PFA Liner suitable in vacuum tube
- High accuracy of +/-0.5% of reading
- With Forward Reverse flowrate measure function



■ Compact Version



■ Separate Version

Specification

Size	10, 15, 20, 25, 32, 40, 50, 65, 80, 100, 125, 150, 200, 250, 300, 350, 400, 450, 500, 600, 700, 800, 900, 1000, 1200, 1400, 1600, 1800, 2000mm
Measuring Range	Velocity 0.3-15m/s min.

Material

Measuring Tube	Stainless Steel 304 Stainless Steel 316 (Option)
Flange	Carbon Steel (standard) Stainless Steel 304 (Option) Stainless Steel 316 (Option)
Coil Housing	Carbon Steel (standard) Stainless Steel 304 (Option) Stainless Steel 316 (Option)
Linear	Neoprene (25-2000mm) Polyurethane (15-600mm) FEP (10-300mm) PTFE (10-2000mm) PFA (20-500mm)
Protection	IP 68 (Submersible)
Conductivity	to be more than 5us/cm

Explosion Proof	Ex d IIC T6 Gb
Electrode & Grounding	Stainless Steel 316L Hastelloy B Hastelloy C Titanium Tantalum Platinum Tungsten Carbide
Cable Entry	2 X PG 11, 1/2 NPT (Option)
Ambient Temperature	-25 to +60 Deg.C
Process Connection	Flange
Flanges Type	JIS 10K / JIS 20K / JIS 40K ANSI 150# / ANSI 300# / ANSI 600# DIN PN 10 / PN 16 / PN 25 / PN 40
Grounding Resistance	Must be less than 10Ω
Temperature	-20~ +80℃ (Neoprene) -20~+60℃ (PU) -25~+120℃ (FEP) -30~+120℃ (PTFE) -30~+120℃ (PFA)
Working Pressure	1.6Mpa (Size 10-150mm) 1.0Mpa (Size 200-900mm) 0.6Mpa (Size 1000-2000mm)

LD Series Electromagnetic Flowmeter

General

KINGTAI MA series Converter can be used with LD series flow tubes in both compact or separate versions

Features

- Two display for Flow rate / Totalizer
- Accuracy of +/-0.5%
- Bi-directional flow measurement. current and pulse output
- MODBUS, HART, GPRS, PROFIBUS communication (Option)
- Chinese or English displaying mode. (other languages can be set)
- Three integrator gross inside. respective register: Forward gross, reverse gross and minus value gross



Rotundity define keys and LCD screen display



Squared define keys and LCD screen display

Standard Specification

● Excitation	Low-frequency square-wave exciting frequency 1/16 power frequency, 1/20 power frequency, 1/25 power frequency, High-frequency square-wave exciting frequency 1/2 power frequency; Exciting current can be selected for 125mA, 187.5mA, 250mA, 500 mA
---------------------	--

L Mag 4Keys and display

● Measuring Range	0 to 15m/s
● Velocity	0.5mm/s
● Repeatability	+/-0.1% of reading
● Current output	4-20mA (Isolated)
● Load	Max.750Ω
● Basic Errors	0.1%±10μA
● Pulse output	Output by field-effect transistors, the highest subjected voltage is 36VDC, maximum of output current is 250 mA.
● Pulse Rate	Frequency range: 15000Hz; Pulse output range: 0 ~ 100 pulse/s (When higher than upper limit, pulse will lose); Pulse output value: 0.001 ~ 1.000m ³ /cp 0.001 ~ 1.000 Ltr / cp
● Pulse output width	50ms
● Alarm output	Alarm output junction ALMH-upper limit; ALML-lower limit; Alarm output drive: output by Darlington pipe, the highest subjected voltage is 36VDC, maximum of output current is 250 mA.

● Digital communication port and protocol	MODBUS interface: format of RTU, RS485 HART interface: designed by standard of HART, if you choose our hand held unit, you can display the measure value on line, and setting the parameters.
--	--

● Low Flow Cutoff	0 to 599.99%
● Damping	1-64
● Self Diagnosis	The following trouble can be alarmed correctly: FQH - Flow high limit alarm; FQL - Flow low limit alarm; GP - Flow empty pipe alarm; SYS - System exciting alarm
● Cable Entry	2-M20*1.5, 1/2NPT (Option)
● Protection Class	IP65 IP67 (Option) IP68 (Battery power supply)
● Ambient Temperature	-10 to +65℃
● Material	Aluminum Alloy
● Power Supply	80-250Vac, 45-63 Hz (single-phase AC) 24Vdc (20VDC-36VDC) Battery
● Power Consumption	<20W (After connecting sensor)

LD-MA Model Selection

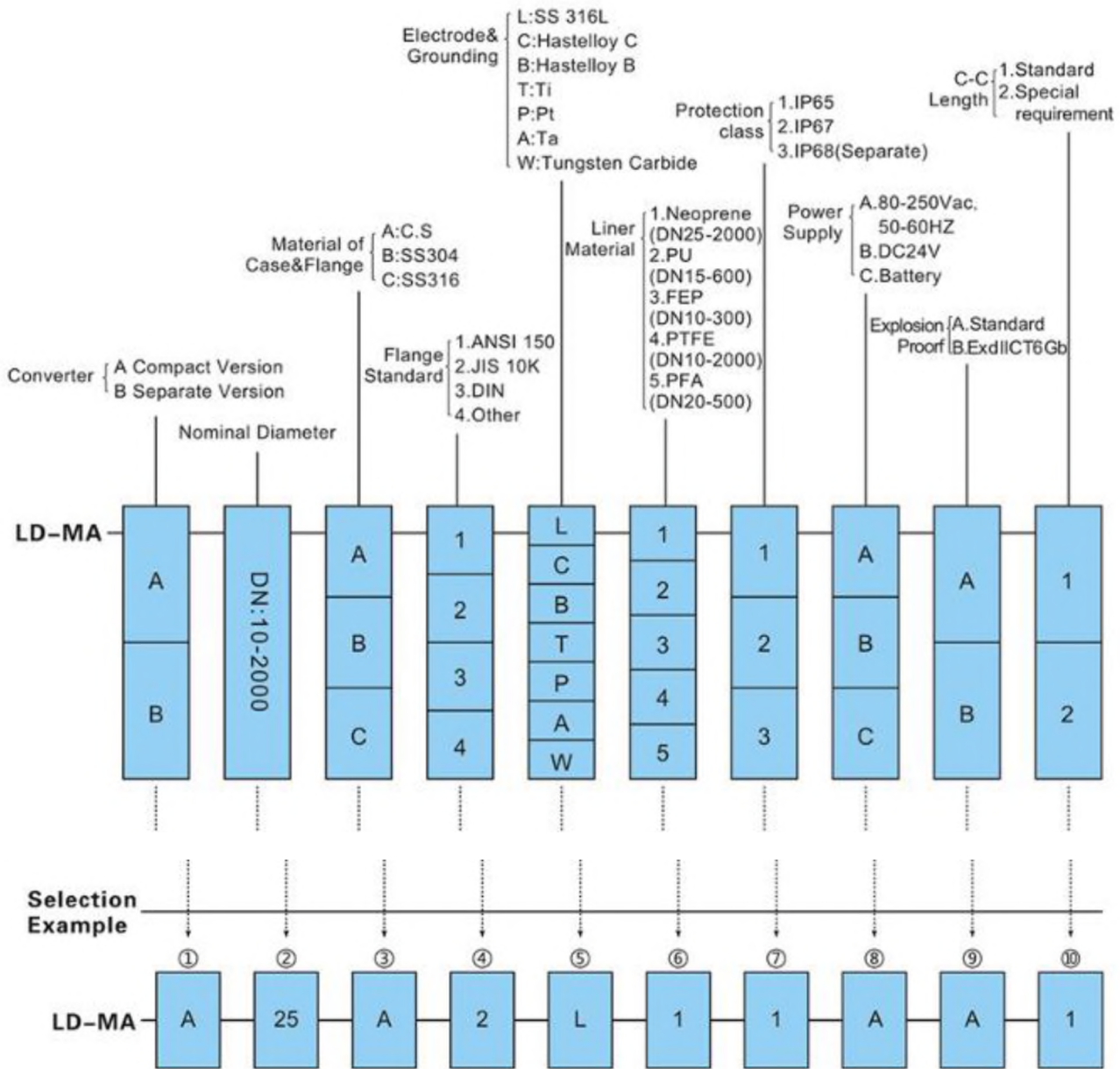

Compact Version: Grey(Standard)

Blue(OPTION)

LD Series Electromagnetic Flowmeter

Flow Selection Table

Caliber(mm)	Minimum Flow Options (m ³ /h)	Common choice of full scale flow range options (m ³ /h)
10	0.10	0.4,0.5,0.6,0.8,1.0,1.2,1.6,2.0,2.5
15	0.20	1.0,1.2,1.6,2.0,2.5,3.0,4.0,5.0,6.0
20	0.35	2.0,2.5,3.0,4.0,5.0,6.0,8.0,10.0,12.0
25	0.55	3.0,4.0,5.0,6.0,8.0,10.0,12.0,14.0,16.0
32	1.0	5.0,6.0,8.0,10.0,12,16,20,25
40	1.5	8.0,10.0,12,16,20,25,30,40
50	2.5	12,16,20,25,30,40,50,60,70
65	4.0	20,25,30,40,50,60,80,100,120
80	5.5	25,30,40,50,60,80,100,120,160
100	8.5	40,50,60,80,100,120,160,200,250
125	14	60,80,100,120,160,200,250,300,400,500,600
150	20	100,120,160,200,250,300,400,500,600
200	35	160,200,250,300,400,500,600,800,1000
250	55	200,250,300,400,500,600,800,1000,1200,1600
300	80	300,400,500,600,800,1000,1200,1600,2000,2500
350	105	400,500,600,800,1000,1200,1600,2000,2500,3000
400	135	500,600,800,1000,1200,1600,2000,2500,3000,4000
450	175	600,800,1000,1200,1600,2000,2500,3000,4000,5000
500	215	800,1000,1200,1600,2000,2500,3000,4000,5000,6000
600	305	1000,1200,1600,2000,2500,3000,4000,5000,6000,1000
700	415	1200,1600,2000,2500,3000,4000,5000,6000,10000,12000
800	545	1600,2000,2500,3000,4000,5000,6000,10000,12000,16000
900	690	2000,2500,3000,4000,5000,6000,10000,12000,16000,20000
1000	850	2500,3000,4000,5000,6000,10000,12000,16000,20000,25000
1200	1250	6000,10000,20000,30000,40000,50000
1400	1700	8000,10000,20000,30000,40000,50000
1600	2500	10000,20000,30000,40000,50000,65000
1800	3000	15000,20000,30000,40000,50000,60000,70000,80000
2000	3500	20000,40000,60000,80000,100000
2200	4000	20000,40000,60000,80000,100000,120000

LD Series Electromagnetic Flowmeter

Dimension (See diagram and drawing below)

Diameter(mm)	A	D	DO	n-Φ
10	200	90	60	4×14
15	200	95	65	4×14
20	200	105	75	4×14
25	200	115	85	4×14
32	200	140	100	4×18
40	200	150	110	4×18
50	200	165	125	4×18
65	250	175	145	8×18
80	250	200	160	8×18
100	250	220	180	8×18
125	250	250	210	8×18
150	300	285	240	8×22
200	350	340	295	8×22
250	400	395	350	12×22
300	460	445	400	12×22
350	460	505	460	16×26
400	600	565	515	16×26
450	600	615	565	20×26
500	600	670	620	20×26
600	600	780	725	20×30
700	600	895	840	20×30
800	800	1015	950	24×33
900	900	1115	1050	24×33
1000	1000	1230	1160	28×33
1200	1200	1405	1340	28×36
1400	1400	1630	1560	32×36
1600	1600	1830	1760	36×36
1800	1800	2045	1970	36×36
2000	2000	2265	2180	48×42
2200	2200	2405	2315	52×45

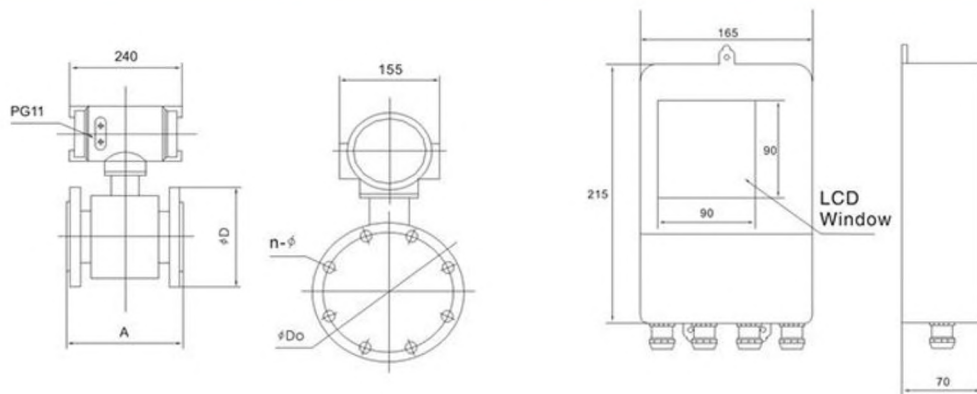

LD Series Electromagnetic Flowmeter

Electrode Material Options

Selection is based on target fluid property

Material	Causticity Resistance
316L	Suitable to: 1. Domestic water, industrial water, head stream and well water, polluted water in cities. 2. Solution of acid, alkali and salt that is of low causticity
Harrington Alloy B	Suitable to: 1. Hydrochloric acid (Concentration<10%), all of alkali concentrations of C,H,NO 2. Sodium hydroxide (Concentration<50%) 3. Calcium phosphate, organic acid. Not suitable to: Nitric acid.
Harrington Alloy C	Suitable to: 1. Mixed acids such as blended liquid of chromate and vitriol 2. Oxidation salts such as Fe ⁺⁺ , Cu ⁺⁺ , seawater Not suitable to: hydrochloric acid
(Ti)	Suitable to: 1. Salts e.g.:(1) Chloride (magnesium/aluminum/calcium/Ti) (2) Sodium, potassium, ammonium, hypochlorite, sea water sea 2. Hydroxide concentration < 50% potassium chloride, ammonium hydroxide, barium hydroxide alkali Not suitable to: Hydrochloric acid, sulfuric acid, phosphoric acid, hydrofluoric acid, alkali cyanide oxidation barium
(Ta)	Suitable to: 1. hydrochloric acid(Concentration<10%) , watery hydrochloric acid and thick vitriol (except for oleum) 2. chlorine dioxide, magnesium chloride, hypochlorous, sodium cyanide, lead acetate etc. 3. acid oxide such as nitric acid(incl oleum) and aqua regia, the temperature of which should lower than 80℃ Not suitable to: alkali, hydrofluoric acid
(Pt)	Suitable to: almost all solution of acids, alkalis and salts (including oleum, fuming nitric acid) Not suitable to: aqua regia, ammonium.

LD Series Electromagnetic Flowmeter

Lining Material Options

Selection is based on causticity,corrosive wearability and temperature of target media.

Lining Material	Name	Abbreviation	Performance	Max.Temp	Applicable liquid	Applicable caliber
Rubber	Chloroprene Rubber	CR	Medium wearability , safe with low concentration of acids, alkalis and salts	<80°C	waten industrial water, water, sea water	DN50~2200
	Polyurethane Rubber	PU	Excellent wear resistance; acid and alkali resistance poor resistance to acids and alkalis.	<60°C	pulp and slurry etc.	DN25~500
Fluoroplastics	Polyfluorotetraethylene	F4 PTFE	Chemical property is stable and is tolerant to boiling hydrochloricacidm,sulfuric acid,aqua regia and strong alkali	<180°C	corrosive liquid alkali salt	DN25~1200
	Teflon	F46 FEP	Chemical properties slightly inferior to F4	<120°C	corrosive liquid alkali salt	DN15~200
	Teflon PFA	PFA	Chemical property is similar to PTFE,good ability of negative pressure	200°C	Resistance strong corrosion resistance such as strong acid strong alkali	DN10-DN500

Location of installation

In order to enable reliable flow meter, PIs note the following installation requirements :

1. As far as possible to avoid ferromagnetic objects and equipment with strong magnetic fields (big electric machine, big transformer) is protecting of the magnetic field sensor.
2. It should be installed in the ventilation in the dry, avoid moist and stagnant water.
3. It should be avoided the solarization and rain , To avoid the environment temperature higher than 60°C and humidity more than 95%
4. Flow meter should be enough space around for easy installation and Maintenance.
5. Flow meter must be installed at the outlet of the pump. valve should be installed at the downstream of the flow meter

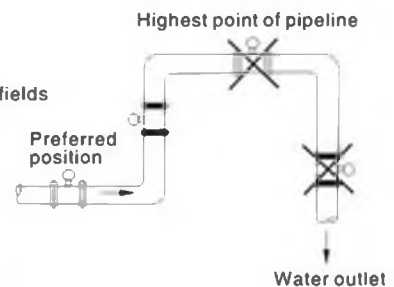

LD Series Electromagnetic Flowmeter

LD Flow Meters Groundings Tips

1. For Mounting to Metal Tubes

Most of the metal tubes are buried and in contact to the ground, fluid is grounded indirectly. Therefore, there is no need to ground the mounting, especially for those of small caliber. However, particular grounding connection will no doubt greatly help reliability of the instrument performance.

2. For mounting to metal tubes with insulated coating, liner, painting to the inner wall or mounting to plastic tubes;

It's essential to fit metal trims and earth rings on both ends of insulated tubes, by which to establish conductivity between fluid and the grounding system. For details, please check Fig.1. In case of caustic fluids, which may hinder the metal parts installation, it's suggested drill holes at both ends of the insulated tubes for installation of grounding electrodes, which shall be made of causticity resistant alloy and connected to grounding screws with sensor in regard.

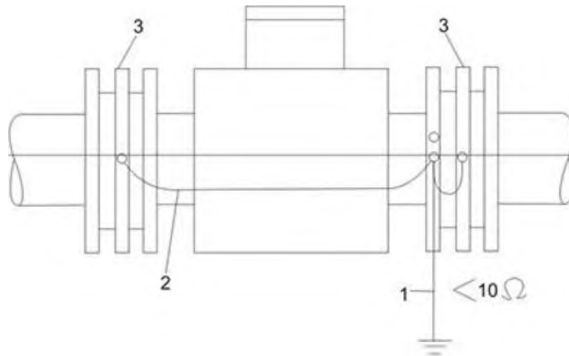

Fig.1 For Mounting to Cathode protected Tubes

- 1-measure grounding;
- 2-grounding lead (16 mm² copper cores);
- 3-grounding rings

3. For Mounting to Cathode Protected Tubes

The following precautions need to be noted for grounding of cathode protected tubes; see Fig.2.

- 1)Sensors should be insulated from tubes with cathode protection, so as to prevent sensing results from any electric potential disturbance;
- 2)Earth rings should be equipped to both end faces of sensor and to be insulated from tube flanges. Earth rings on both sides need to be connected to the sensor, while insulated from tube.
- 3)Tube flanges on sides should be wired up with 16mm² copper cores bypassing the sensor.
- 4)Penetrating bolts for flange coupling should be insulated from the flanges with insulated liner and gaskets. Please see Fig.3.

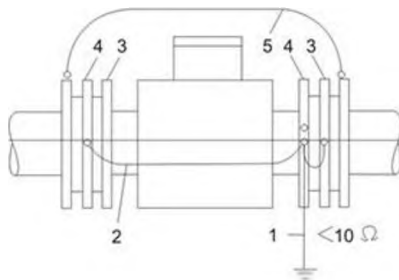

Fig.2 Sensor Mounting at Cathode Protected Tubes

- 1-measure grounding;
- 2-grounding lead (16mm² copper cores);
- 3-earth ring;
- 4-bolt (insulated);
- 5-connection wire (16mm² copper cores).

LD Series Electromagnetic Flowmeter

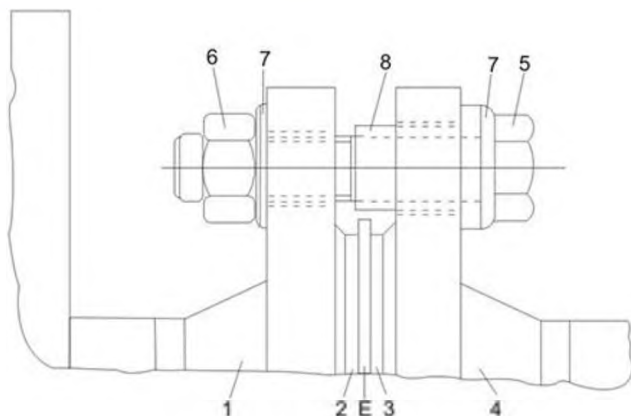

Fig.3 Insulated Bolts in Cathode Protected Tube E-earth ring;

- 1-flanges with sensor;
- 2-liner (PTFE);
- 3-O-ring;
- 4-piping flanges;
- 5-bolt;
- 6-nut;
- 7-gasket;
- 8-insulating liner.

4.For Mounting at Places with Strong Stray Current

For mounting at places with strong stray current e.g. to measure electrolytes flow in tubes by electrolytic cells, where stray current influences reading seriously. It's suggested follow the grounding installation shown in Fig.4, which is to cap both ends of the sensor with earth rings and insulating trims. Similar to other grounding installations, both the earth rings and flanges of the sensor shall be connected to secured grounding rods; however, all other structure tubes by the insulated tubes shall be bypassed by wiring. Since most of creeps has been bypassed via copper cores, disturbance to signaling circuits is hence eliminated.

For mounting at places with strong creeps or electric fields, sensors have to be grounded independently to grounding rod buried in certain depth with copper cores of no less than 16mm².

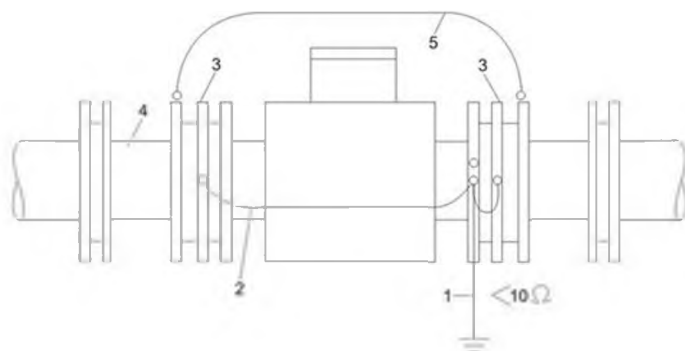

Fig.4 Sensor Mounted to a Tube with Strong Stray Current

- 1-measure grounding;
- 2-grounding lead (16mm² copper cores);
- 3-earth rings;
- 4-insulating trims;
- 5-connection wire (16mm² copper cores)

По вопросам продаж и поддержки обращайтесь:

Архангельск (8182)63-90-72
 Астана +7(7172)727-132
 Астрахань (8512)99-46-04
 Барнаул (3852)73-04-60
 Белгород (4722)40-23-64
 Брянск (4832)59-03-52
 Владивосток (423)249-28-31
 Волгоград (844)278-03-48
 Вологда (8172)26-41-59
 Воронеж (473)204-51-73
 Екатеринбург (343)384-55-89
 Иваново (4932)77-34-06
 Ижевск (3412)26-03-58
 Иркутск (395) 279-98-46
 Киргизия (996)312-96-26-47

Казань (843)206-01-48
 Калининград (4012)72-03-81
 Калуга (4842)92-23-67
 Кемерово (3842)65-04-62
 Киров (8332)68-02-04
 Краснодар (861)203-40-90
 Красноярск (391)204-63-61
 Курск (4712)77-13-04
 Липецк (4742)52-20-81
 Магнитогорск (3519)55-03-13
 Москва (495)268-04-70
 Мурманск (8152)59-64-93
 Набережные Челны (8552)20-53-41
 Нижний Новгород (831)429-08-12
 Казахстан (772)734-952-31

Новокузнецк (3843)20-46-81
 Новосибирск (383)227-86-73
 Омск (3812)21-46-40
 Орел (4862)44-53-42
 Оренбург (3532)37-68-04
 Пенза (8412)22-31-16
 Пермь (342)205-81-47
 Ростов-на-Дону (863)308-18-15
 Рязань (4912)46-61-64
 Самара (846)206-03-16
 Санкт-Петербург (812)309-46-40
 Саратов (845)249-38-78
 Севастополь (8692)22-31-93
 Симферополь (3652)67-13-56
 Таджикистан (992)427-82-92-69

Смоленск (4812)29-41-54
 Сочи (862)225-72-31
 Ставрополь (8652)20-65-13
 Сургут (3462)77-98-35
 Тверь (4822)63-31-35
 Томск (3822)98-41-53
 Тула (4872)74-02-29
 Тюмень (3452)66-21-18
 Ульяновск (8422)24-23-59
 Уфа (347)229-48-12
 Хабаровск (4212)92-98-04
 Челябинск (351)202-03-61
 Череповец (8202)49-02-64
 Ярославль (4852)69-52-93